

Elakeview Enterprise LTD

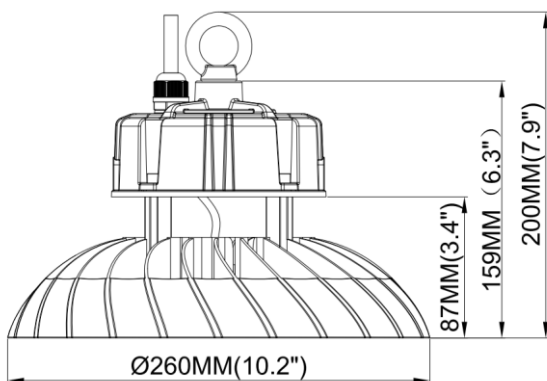

LED UFO Highbay

LED UFO Highbay is designed for commercial and industrial applications where dustproof and waterproof lighting fixtures are required. Its stylish design and modern profile work perfectly for high bay/low bay lighting. Suitable for a wide range of environments from repair shops, garages, retail stores, hockey rinks and food processing facilities.



Features

- Wide input voltage options from 120-277V and 347V
- Stylish and modern profile. High impact polycarbonate lens
- High lumen efficiency and low glare: >155LMW
- Fully weatherproof IP65, resistant to vibration
- 0-10V dimming
- With 6 feet leads

Options

- Microwave dimming occupancy sensor available
- 4000K and 5000K available
- 90 degree Reflector available

Construction

- Die Cast Aluminum housing
- Powder-coated finish
- Impact resistant, high grade polycarbonate lens

Approvals

- cUL listed
- DLC Premium listed
- IP65 rated

Operating Temperature

- -35 C to 50C

Warranty

- Standard 5 years. Extended warranty available

Specifications & Order info

Order SKU	Model No.	Description	Input Voltage(AC)	System Lumens	Efficacy	CRI	PF	THD	Dimension (MM)	N.W
900038	HBU100WUNV40K	LED High Bay UFO , 100W, AC120-277V, 16000LM, 4000K	120-277V	15778.30LM	>0.95	>80	>0.95	<15	260*200	2.7kg
900039	HBU100WUNV50K	LED High Bay UFO , 100W, AC120-277V, 16000LM, 5000K	120-277V	15778.30LM	>0.95	>80	>0.95	<15	260*200	2.7kg
900040	HBU100W34740K	LED High Bay UFO , 100W, AC347-480V, 16000LM, 4000K	347-480V	15778.30LM	>0.95	>80	>0.95	<15	260*200	2.8kg
900041	HBU100W34750K	LED High Bay UFO , 100W, AC347-480V, 16000LM, 5000K	347-480V	15778.30LM	>0.95	>80	>0.95	<15	260*200	2.8kg

